

ICONOPOWER Standard Clamps

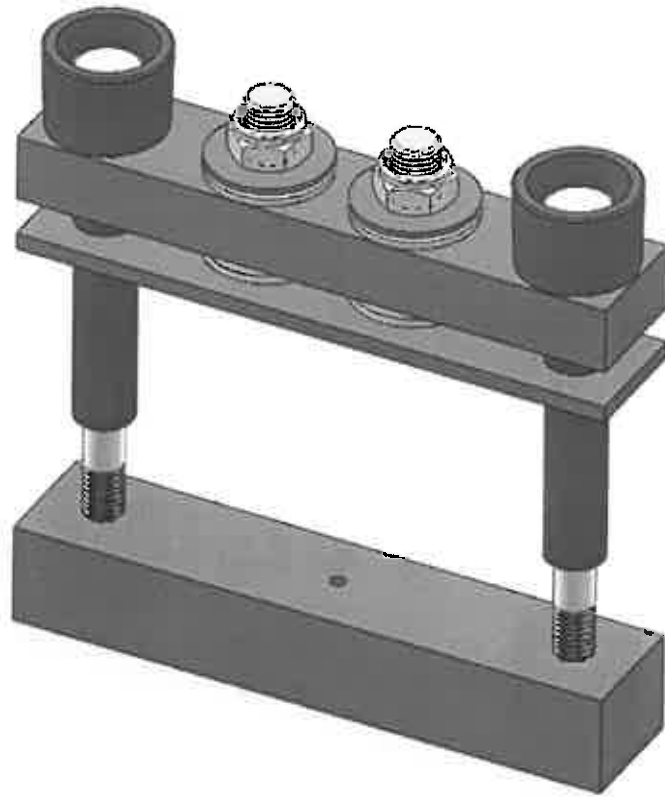

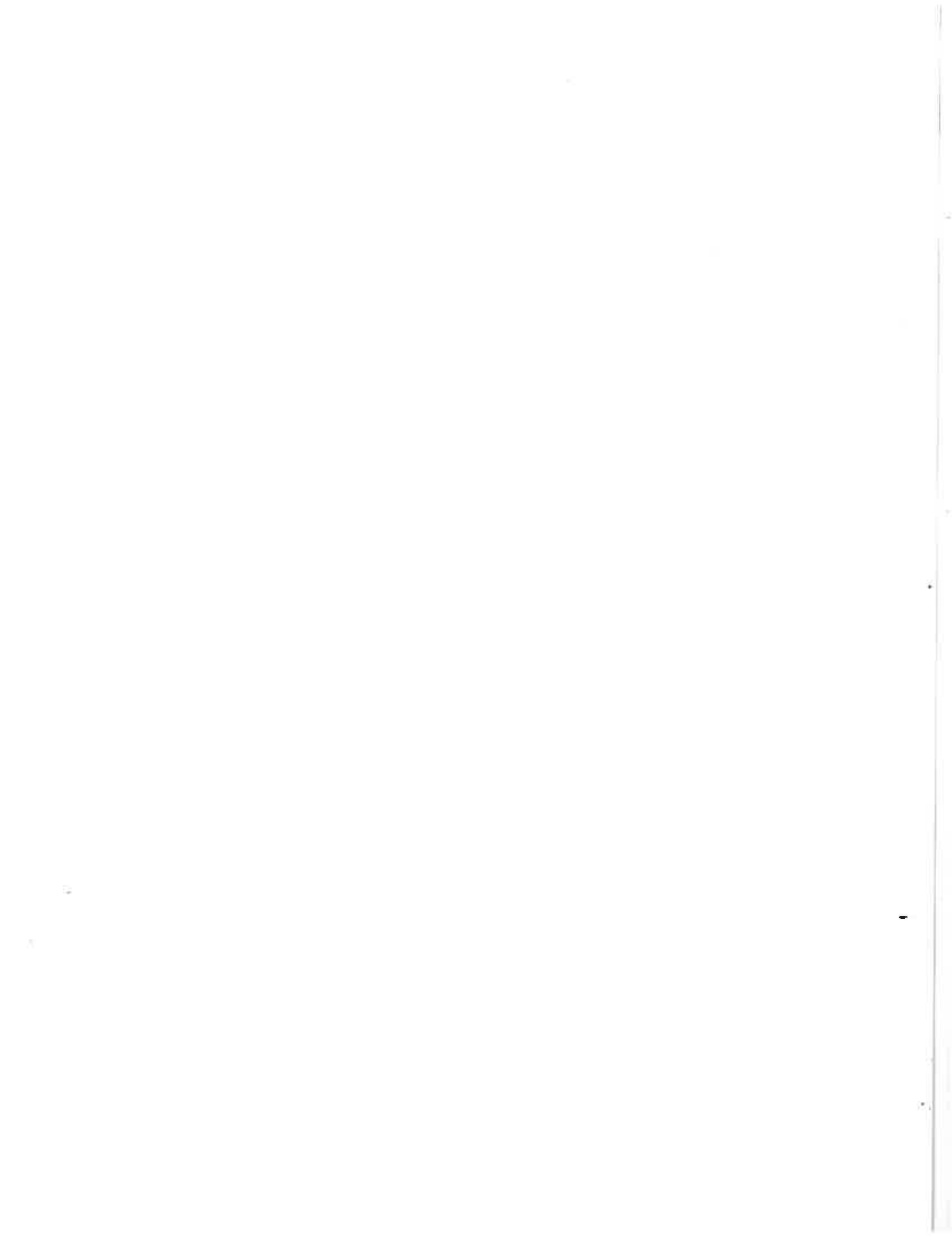

Introduction:

This document/guide will help through the selection of Bar type clamps used with disc or 'puck' style Diodes and SCR's. The Bolt centers range from 54mm to 200mm and the clamping pressure / force ranges from 5kN to 120kN at voltages up to 2500V AC as a standard, however different Bolt centers and higher pressure ratings and voltages are available as specials.

What is a Semiconductor Clamp?

A semiconductor clamp is a clamping mechanism used to provide even rated pressure for the proper operation of the semiconductor device. It also maintains the pressure for a prolonged proper usage of the device. Clamps can be used with variety of heat sinks and bus bars to provide and maintain adequate surface contact area for better conductivity, both electrical and thermal.

There are several variables that must be kept in mind to properly choose a clamp for a project. This document will guide/help through all the variables and also show one example on how to choose a clamp for the right application.

Clamp selection terminologies and descriptions:

To understand the clamp selection process, following is a review some of the terminologies and abbreviations used. Then, a sample example is shown within the guide to select the correct clamp required for a specific job.

1. Max Cell Diameter:

This is the diameter of the largest portion of the device. Most semiconductor devices are designed with a Cathode flange and that is larger than the actual device body. This diameter would be the one used in choosing the correct bolt centers.

2. Bolt Centers:

This is the center to center bolt spacing of a clamp. Although the clamp bolt spacing is a factor for the manufacturer's design, Iconopower has taken into consideration the standard semiconductor package sizes and their common kN ratings, thus providing a cost effective and quicker solution. (Eg: IC102 series indicates 102mm bolt centre spacing).

3. Clamping force:

This clamping pressure is specified by the semiconductor manufacturer for each specific device. This value is indicated on the device datasheet. If the pressure applied to the device is insufficient, there is a decrease in current carrying capabilities of the device and there is a large increase in temperature of the device. These factors can also create hot spots on the silicon wafer chip causing premature failure of the semiconductor. Subsequently, too much pressure can physically damage the device internally. The specifications are normally expressed in kN (kilo Newton), Kgf (kilogram force) or PSI (pounds per square inch)

4. Clamping distance / 'Z' Dimension:

This is the sum of max dimension of the parts that need to be clamped. A simple example would be, if there is a 1" device with double sided cooling using two 1" thick heat sinks, the clamping distance would be $1" + 1" + 1" = 3"$. All Iconopower clamp designs have a table associated with each range, providing information of clamp distances available as a standard. This area is identified as 'Z' dimension and the range would be denoted as Z max and Z min.

Before Selecting a clamp:

The following clamp selection process is to select an appropriate clamp to suite the project. The clamp selection begins by knowing the device intended to be used and the dimensions of the cooling medium used to maintain proper temperature for the device. Most manufacturers provide the information on their website via data sheets.

There are three categories for Clamp assembly users:

1. Direct Replacement users
2. Replacement with modifications users
3. New Design users

Following is the information required before selection a clamp:

1. Device diameter
2. Clamp bolt center spacing
3. Style of clamp required
4. Device kN (pressure) range
5. "Z" dimension / Clamping Distance

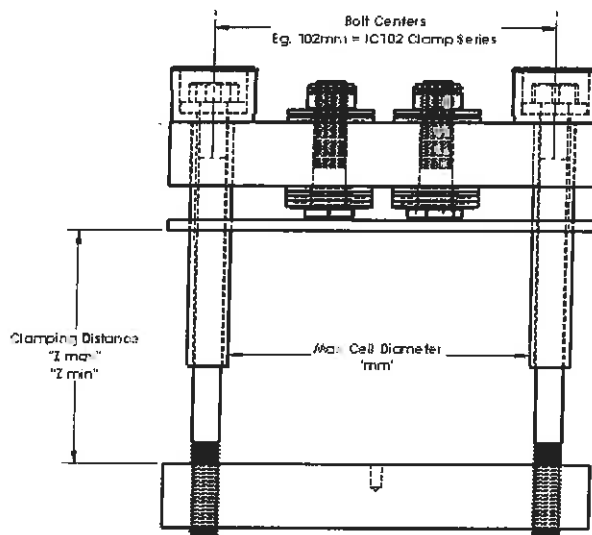

Fig. 1 - Clamp Dimensions

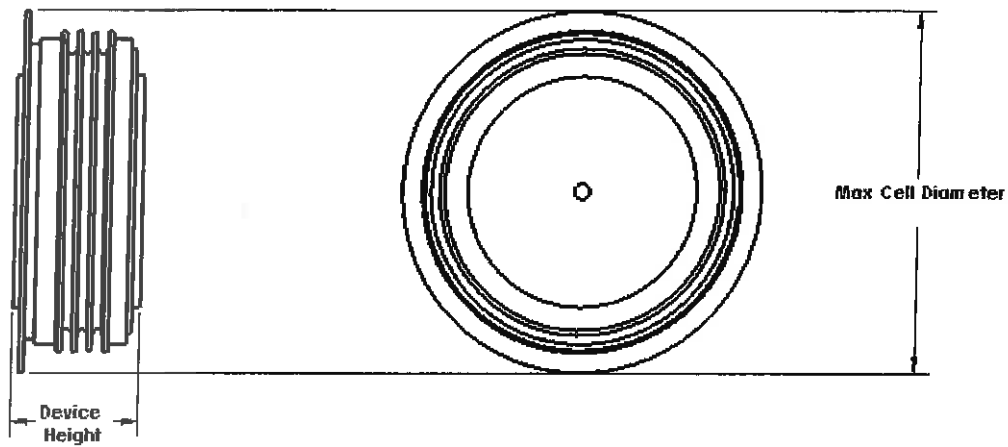

Fig. 2 - Device Nomenclature

Iconopower's standard line of clamps is listed below in Table 1. Clamps are categorized by Bolt Centers and kN rating. If the project requires different size or kN rating, please contact Iconopower for further information.

Clamp Series	Max Cell Dia	Styles	Clamping Pressure (Force)																	
			(kN)																	
54	42	C, D, F	5	9																
65	54	C, D, F		9																
70	55	C, D, F	5	9	15															
79	65	C, D, F	5	9	15															
89	75	C, D, F		9	15	22														
102	86	C, D, F			15	22		30												
118	103	C, D				22			32		40									
132	112	C, D					28		32	38		45								
140	120	C, D								38		45	50							
146	126	C, D								38		45	50							

Table 1 – Iconopower Standard Clamps

Iconopower standard clamps are available in mainly three styles, 'C', 'D' and 'F'. The 'C' style is the most common style as it uses bars on both sides of the device and can be used in most of the equipments. The 'D' style is used mainly for single side cooling projects and also where the bottom heat sink is threaded. The 'F' style uses fully threaded rods which gives a larger range of 'Z' dimension. As these styles are provided as standards, clamps can be configured in different arrangements on request.

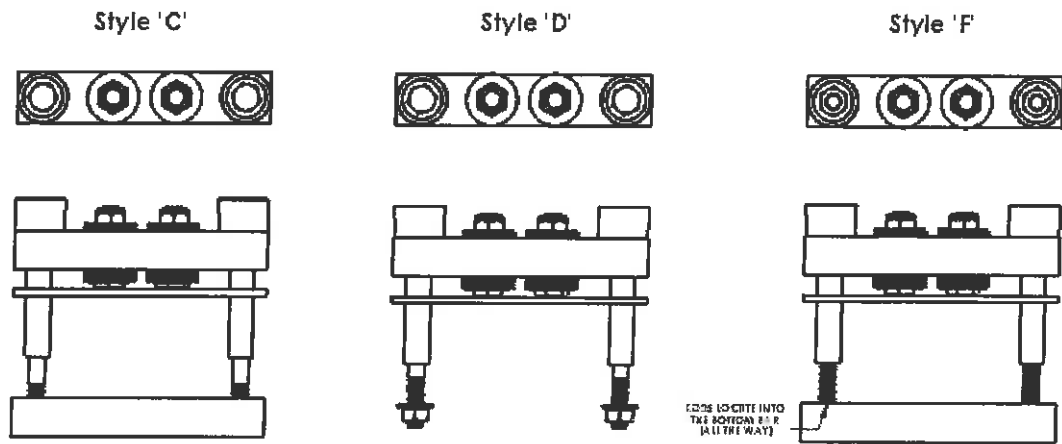
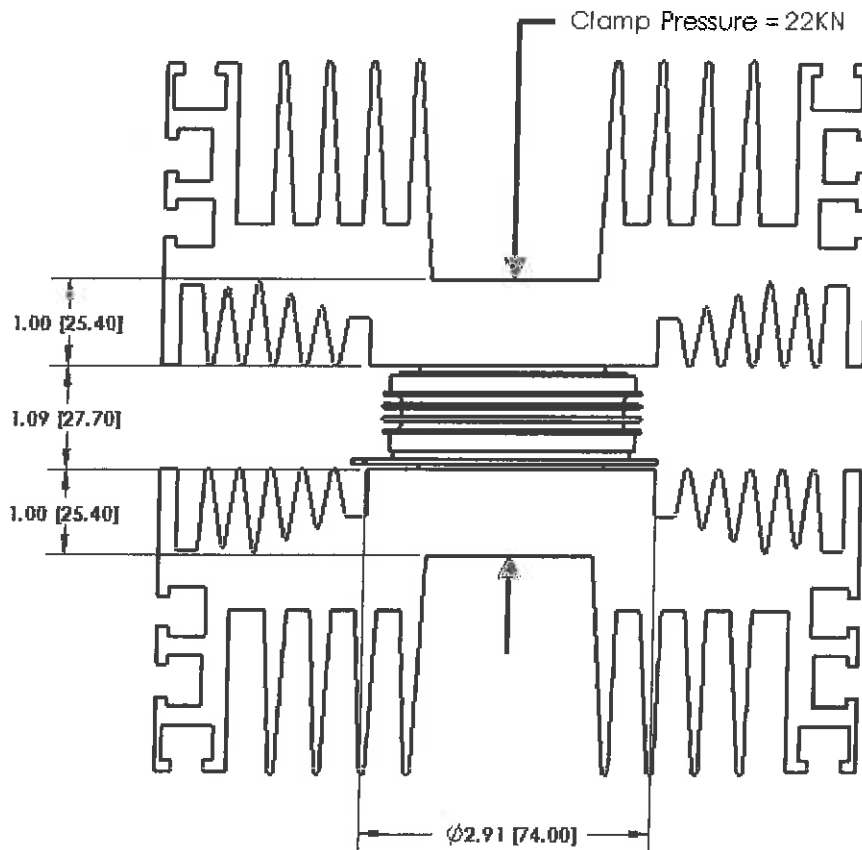

Fig. 3 – Clamp Styles

Clamp Selection Example:

In this example, the following information will be considered:

- | | | |
|---|---|---------|
| 1. Max Cell Diameter | = | 75mm |
| 2. Required Clamping Pressure | = | 22kN |
| 3. Device thickness | = | 1.026in |
| 4. Heat Sink web thickness | = | 1.00in |
| 5. Device requires double sided cooling | = | Yes |



Part number Selection Process

1. Looking at table 1, we can note that for this device, IC89 series could be used but as there is only 1mm difference, IC102 series would be the best choice for this certain device. Part number – IC102
2. Since double side cooling is required, we require two heat sinks with the device in between. The choice of clamp configuration depends on the equipment design, direction and overall height of the clamp but for an example, a 'C' style clamp can be used. The 'C' style uses clamping bars on both sides of the clamp. Part number – IC102C
3. The next step is to determine the clamping pressure. As per the data sheet of the device, the clamping pressure should be in the range of 19kN to 24kN. Now looking at Table 1, we can note that IC102 clamp is offered at 22kN as a standard and that the force sits near the higher limit of the range, which is preferred, so 22kN is chosen as the force. Part number – IC102C22
4. The last step is to determine the clamping distance, the 'Z' dimension. This distance can be calculated by adding the thickness of all the parts used between the clamp. In this case, the clamping distance would be 3.09" (1" + 1.09" + 1"). This distance is denoted by alphabets and the list is included with each series. For this clamp, the 'Z' is 3.09", so clamp used will have 'Z' of 3.00" to 3.25". Part number – IC102C22L

A review of this part number tells us the following information:

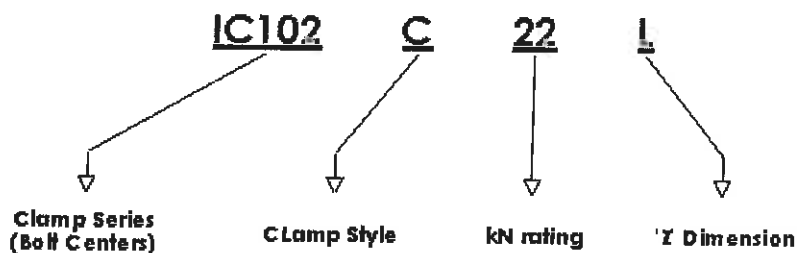

Assembly Procedure for Iconopower Capsule Clamps

The Iconopower precision clamp is constructed with a two or three bolt system with belleville washers used to give the clamping force on the device. This force is achieved when the two top belleville washers are just free to move. **This pre-calibrated force indicator eliminates the need for any special equipment or torque wrenches.**

High force Clamp Recommendation (42kN and higher forces)

Before installing the clamp into the assembly, we recommend the follow procedure be used to reduce the torsion stress and friction that will be felt during the tightening process. This will ensure the torque required for the tightening process will be reduced to a manageable level.

1. Apply a small amount of grease between the threads in the bottom bar.
2. Apply a small amount of grease between the clamp bolt head, and the insulator cup washer.

A general purpose, high temperature grease is suitable for this application.

Clamping Procedure

1. After loosely assembling all the components with the capsule device between the heatsinks, finger tighten the two or three bolts.
2. Check that the top bar is parallel with the heatsink and make sure that it is centrally located, i.e. not at an angle to the channel in the heatsink.
3. (i) Two bolt clamps

Using a socket spanner (wrench) tighten each bolt by a quarter turn alternately until the two top belleville washers are just free to move.

(ii) Three bolt clamps

Using a socket spanner (wrench) tighten each bolt by a quarter turn, centre first then two outer bolts alternately until the two top belleville washers on both sides are just free to move.

Please feel free to contact Iconopower if any further details are required.

Iconopower Clamp Selector Form

Company Information

Name

Company Name

Telephone

Date

Email

City

Device Information

Part number

Annual Usage

Clamp Information

Style

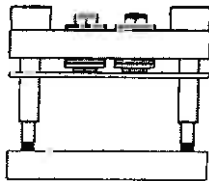

[C]

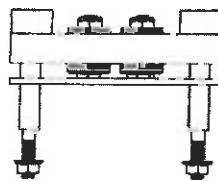

[D]

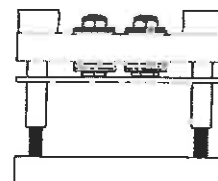

[F]

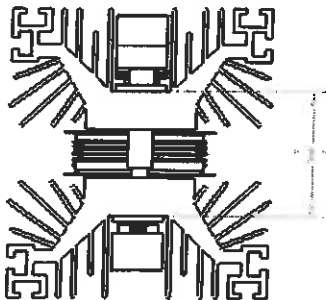

"Z" Dimension

in

mm

Bolt Centres

in

mm

Mounting Force

lbs

kN

Device Height

in

mm

Flange dimension

in

mm

Style Preferred

Notes

IC54 Series

Style 'C'

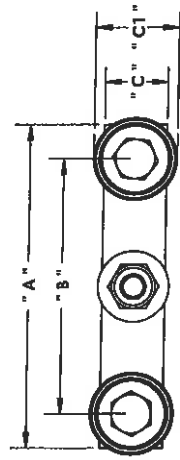

Style 'D'

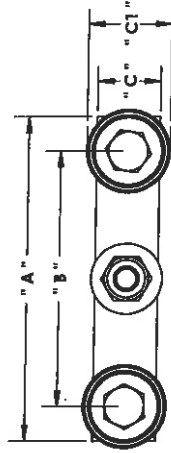

Style 'F'

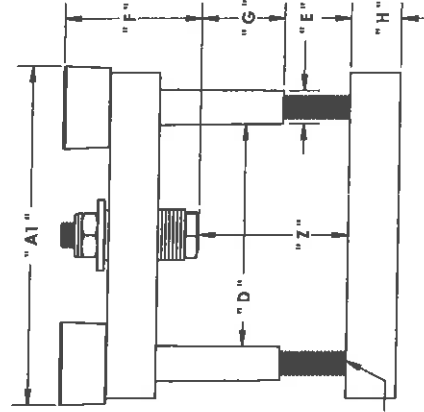
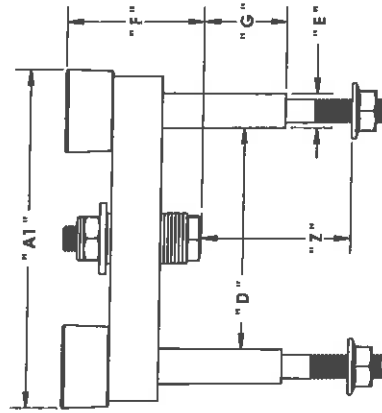
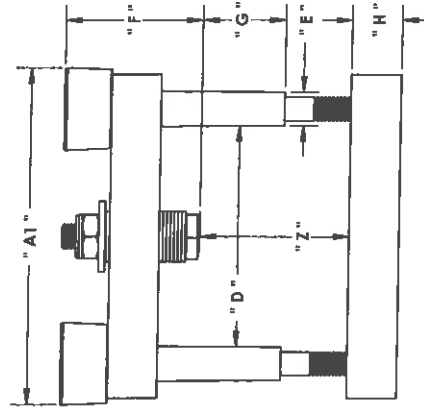
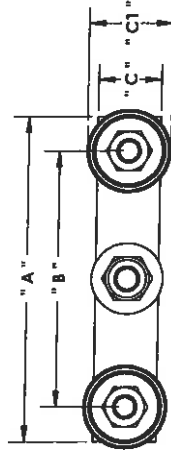

RODS LOCTITE INTO
THE BOTTOM BAR
(ALL THE WAY)

IC 54 Bolt Centre X Style XX Force X " Z "

" A " = 2.75 [69.85]
 " A1 " = 2.95 [74.89]
 " B " = 2.13 [54.00]
 " C " = 0.63 [15.88]
 " C1 " = 0.83 [21.04]
 " D " = 1.65 [42.00]
 " H " = 0.50 [12.70]

Part #'s	" Z " min	" Z " max	" G " (ref)	
			5kN	9kN
IC54 x xx B	0.75 [19.05]	1.00 [25.40]	0.59 [14.98]	0.47 [11.93]
IC54 x xx C	1.00 [25.40]	1.25 [31.75]	0.59 [14.98]	0.67 [17.01]
IC54 x xx D	1.25 [31.75]	1.50 [38.10]	0.78 [19.81]	0.75 [19.05]
IC54 x xx E	1.50 [38.10]	1.75 [44.45]	0.86 [21.84]	0.87 [22.09]
IC54 x xx F	1.75 [44.45]	2.00 [50.80]	0.98 [24.89]	1.06 [26.92]
IC54 x xx G	2.00 [50.80]	2.25 [57.15]	1.18 [29.97]	1.14 [28.95]
IC54 x xx H	2.25 [57.15]	2.50 [63.50]	1.26 [32.00]	1.26 [32.00]
IC54 x xx J	2.50 [63.50]	2.75 [69.85]	1.37 [34.79]	1.46 [37.08]
IC54 x xx K	2.75 [69.85]	3.00 [76.20]	1.57 [39.87]	1.46 [37.08]

Force [kN]	" E "	" F " (ref)	Bolt Type
5	0.34 [8.64]	1.26 [32.00]	M6
9	0.34 [8.64]	1.38 [35.05]	M6

- * All dimensions are in Inches [Millimeters].
- * Modifications available on request.
- * Our standard is Metric but imperial can be accommodated.
- * "Ref" dimensions due to compression of springs.

IC65 Series

Style 'C'

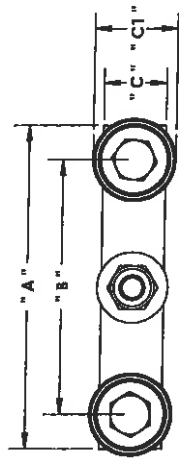

Style 'D'

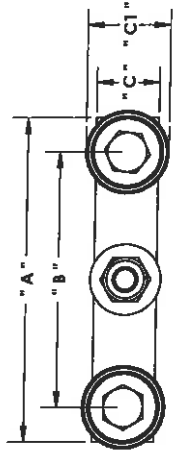

Style 'F'

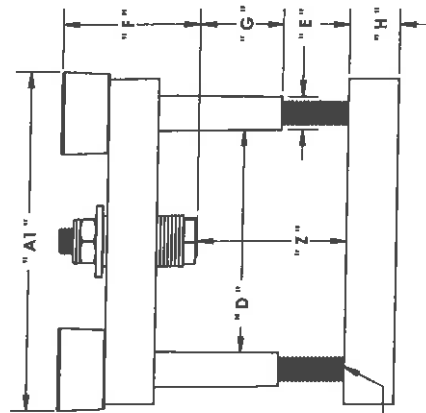
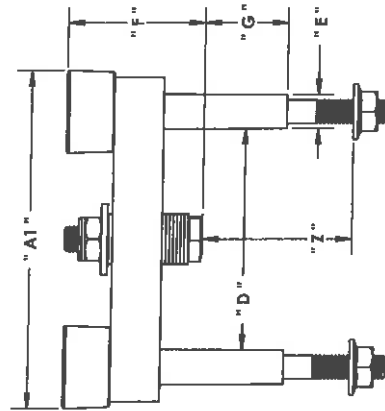
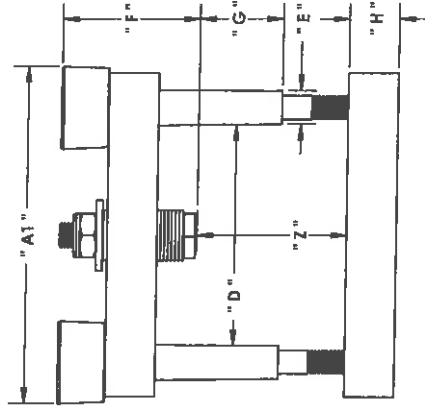
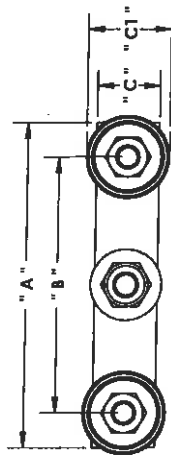

RODS LOCTITE INTO
THE BOTTOM BAR
(ALL THE WAY)

IC 65 X X X X X
 Bolt Centre Style Force " Z "

" A " = 3.25 [82.55]
 " A1 " = 3.39 [86.04]
 " B " = 2.56 [65.00]
 " C " = 0.63 [15.88]
 " C1 " = 0.83 [21.04]
 " D " = 2.12 [54.00]
 " H " = 0.50 [12.70]

Part #'s	" Z " min	" Z " max	" G " (ref)
IC65 x x B	0.75 [19.05]	1.00 [25.40]	9kN
IC65 x x C	1.00 [25.40]	1.25 [31.75]	0.59 [14.98]
IC65 x x D	1.25 [31.75]	1.50 [38.10]	0.71 [18.03]
IC65 x x E	1.50 [38.10]	1.75 [44.45]	0.83 [21.08]
IC65 x x F	1.75 [44.45]	2.00 [50.80]	0.95 [24.13]
IC65 x x G	2.00 [50.80]	2.25 [57.15]	1.06 [26.92]
IC65 x x H	2.25 [57.15]	2.50 [63.50]	1.18 [29.97]
IC65 x x J	2.50 [63.50]	2.75 [69.85]	1.30 [33.02]
IC65 x x K	2.75 [69.85]	3.00 [76.20]	1.46 [27.08]

Force [kN]	" E "	" F " (ref)	Bolt Type
9	0.34 [8.62]	1.38 [34.93]	M6

- * All dimensions are in inches [Millimeters].
- * Modifications available on request.
- * Our standard is Metric but imperial can be accommodated.
- * "Ref" dimensions due to compression of springs.

IC70 Series

Style 'C'

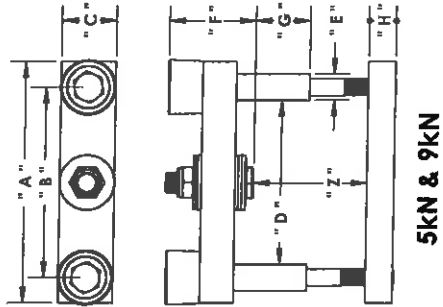

Style 'D'

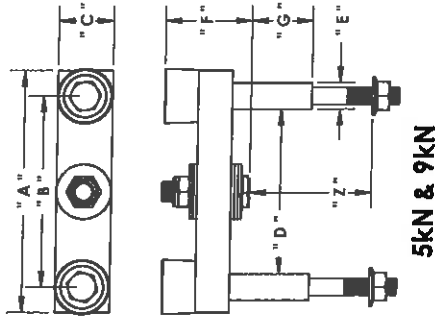

Style 'F'

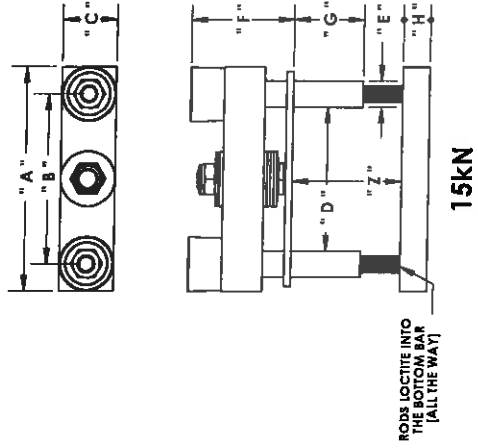
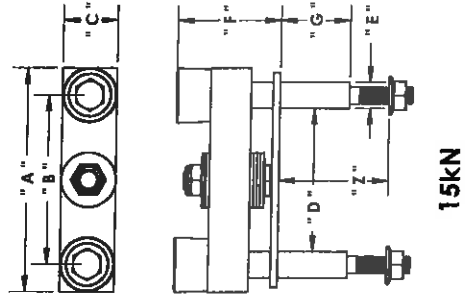
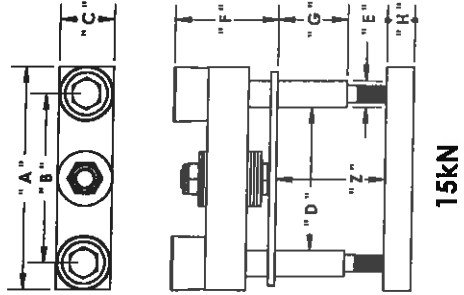
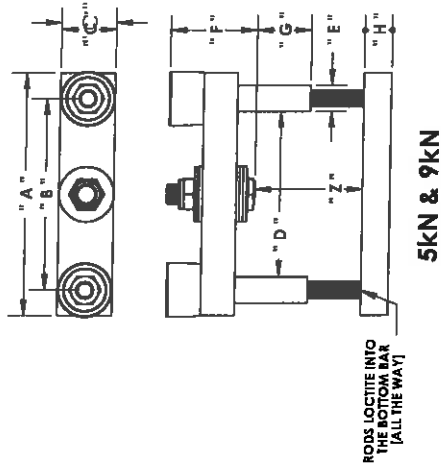

IC 70 X XX X
 Bolt Centre Style Force "Z"

"A" = 3.75 [95.25]
 "B" = 2.76 [70.00]
 "C" = 1.00 [25.40]
 "D" = 2.20 [56.00]
 "H" = 0.38 [9.53]

Force [kN]	"E"	"F" (ref)	Bolt Type
5	0.48 [12.19]	1.29 [32.74]	M8
9	0.48 [12.19]	1.60 [40.55]	M8
15	0.48 [12.19]	1.78 [45.30]	M8

Part #'s	"Z" min	"Z" max	"G" (ref)		
			5kN	9kN	15kN
IC70 x XX D	1.25 [31.75]	1.50 [38.10]	0.80 [20.32]	0.81 [20.57]	1.01 [25.65]
IC70 x XX E	1.50 [38.10]	1.75 [44.45]	0.92 [23.36]	0.92 [23.36]	1.13 [28.70]
IC70 x XX F	1.75 [44.45]	2.00 [50.80]	1.03 [26.16]	1.04 [26.41]	1.29 [32.76]
IC70 x XX G	2.00 [50.80]	2.25 [57.15]	1.11 [28.19]	1.16 [29.46]	1.41 [35.81]
IC70 x XX H	2.25 [57.15]	2.50 [63.50]	1.31 [33.27]	1.32 [33.52]	1.52 [38.60]
IC70 x XX J	2.50 [63.50]	2.75 [69.85]	1.43 [36.32]	1.44 [36.57]	1.60 [40.64]
IC70 x XX K	2.75 [69.85]	3.00 [76.20]	1.51 [38.35]	1.51 [38.35]	1.72 [43.68]
IC70 x XX L	3.00 [76.20]	3.25 [82.55]	1.70 [43.18]	1.67 [42.41]	1.84 [46.73]
IC70 x XX M	3.25 [82.55]	3.50 [88.90]	1.78 [45.21]	1.79 [45.46]	1.96 [49.78]
IC70 x XX N	3.50 [88.90]	3.75 [95.25]	1.90 [48.26]	1.91 [48.51]	2.07 [52.57]
IC70 x XX P	3.75 [95.25]	4.00 [101.60]	2.02 [51.30]	2.03 [51.56]	2.19 [55.62]
IC70 x XX Q	4.00 [101.60]	4.25 [107.95]	2.10 [53.34]	2.18 [55.37]	2.31 [58.67]
IC70 x XX R	4.25 [107.95]	4.50 [114.30]	2.22 [56.38]	2.22 [56.38]	2.43 [61.72]
IC70 x XX S	4.50 [114.30]	4.75 [120.65]	2.33 [59.18]	2.38 [60.45]	2.55 [64.77]

- * All dimensions are in Inches [Millimeters].
- * Modifications available on request.
- * Our standard is Metric but imperial can be accommodated.
- * "Ref" dimensions due to compression of springs.

IC79 Series

Style 'C'

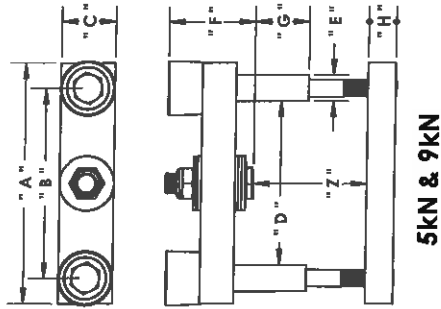

Style 'D'

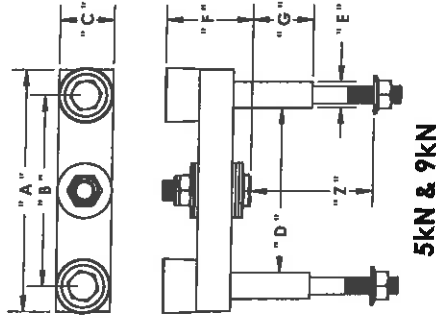

Style 'F'

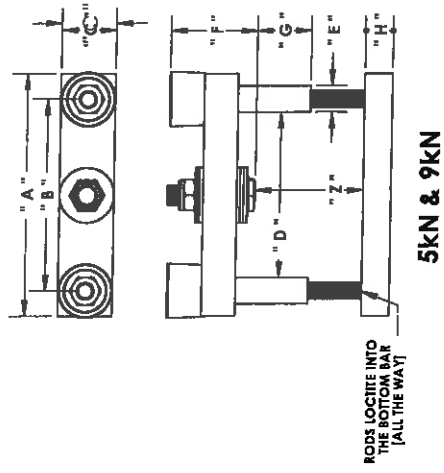

Style 'C'

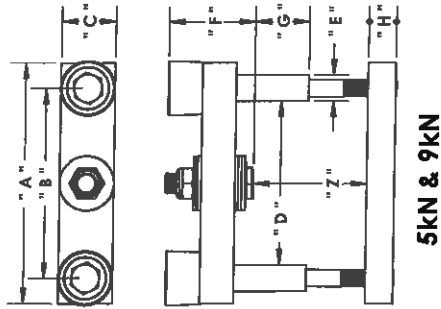

Style 'D'

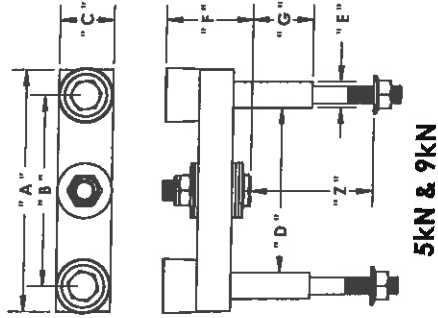

Style 'F'

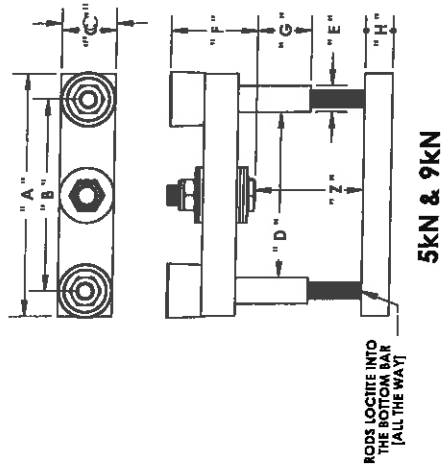

IC 79 X XX X
 Bolt Centre Style Force "Z"
 "Z"

"A" = 4.11 [104.39]
 "B" = 3.11 [79.00]
 "C" = 1.00 [25.40]
 "D" = 2.56 [65.00]
 "H" = 0.50 [12.70]

Force [kN]	"E"	"F" (ref)	Bolt Type
5	0.48 [12.19]	1.66 [42.14]	M8
9	0.48 [12.19]	1.72 [43.72]	M8
15	0.48 [12.19]	1.91 [48.48]	M8

Part #'s	"Z" min	"Z" max	"G" (ref)		
			5kN	9kN	15kN
IC79 x XX D	1.25 [31.75]	1.50 [38.10]	0.78 [19.81]	0.81 [20.57]	1.01 [25.65]
IC79 x XX E	1.50 [38.10]	1.75 [44.45]	0.90 [22.86]	0.92 [23.36]	1.13 [28.70]
IC79 x XX F	1.75 [44.45]	2.00 [50.80]	1.02 [25.90]	1.04 [26.41]	1.29 [32.76]
IC79 x XX G	2.00 [50.80]	2.25 [57.15]	1.14 [28.95]	1.16 [29.46]	1.41 [35.81]
IC79 x XX H	2.25 [57.15]	2.50 [63.50]	1.25 [31.75]	1.32 [33.52]	1.52 [38.60]
IC79 x XX J	2.50 [63.50]	2.75 [69.85]	1.37 [34.79]	1.44 [36.57]	1.60 [40.64]
IC79 x XX K	2.75 [69.85]	3.00 [76.20]	1.45 [36.83]	1.51 [38.35]	1.72 [43.68]
IC79 x XX L	3.00 [76.20]	3.25 [82.55]	1.64 [41.65]	1.67 [42.41]	1.84 [46.73]
IC79 x XX M	3.25 [82.55]	3.50 [88.90]	1.73 [43.94]	1.79 [45.46]	1.96 [49.78]
IC79 x XX N	3.50 [88.90]	3.75 [95.25]	1.85 [46.99]	1.91 [48.51]	2.07 [52.57]
IC79 x XX P	3.75 [95.25]	4.00 [101.60]	1.96 [49.78]	2.03 [51.56]	2.19 [55.62]
IC79 x XX Q	4.00 [101.60]	4.25 [107.95]	2.08 [52.83]	2.18 [55.37]	2.31 [58.67]
IC79 x XX R	4.25 [107.95]	4.50 [114.30]	2.20 [55.88]	2.22 [56.38]	2.43 [61.72]
IC79 x XX S	4.50 [114.30]	4.75 [120.65]	2.32 [58.92]	2.38 [60.45]	2.55 [64.77]

* All dimensions are in Inches [Millimeters].

* Modifications available on request.

* Our standard is Metric but imperial can be accommodated.

* "Ref" dimensions due to compression of springs.

IC89 Series

Style 'C'

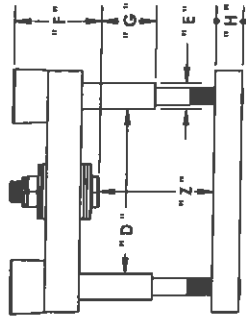
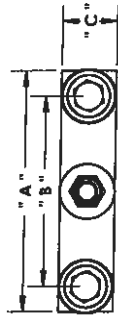

9kN & 15kN

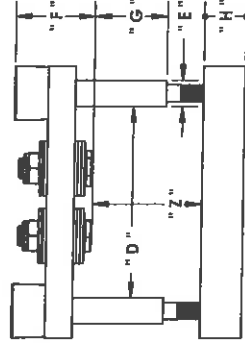
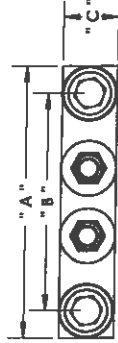

22kN

Style 'D'

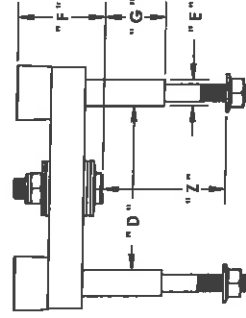
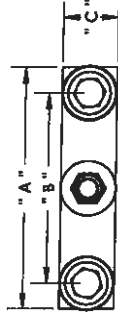

9kN & 15kN

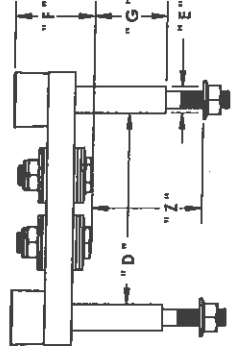
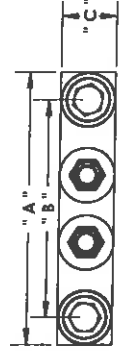

22kN

Style 'F'

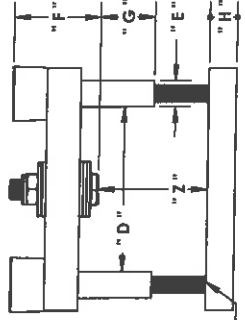
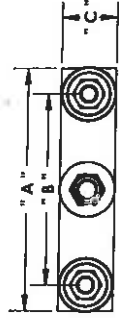

9kN & 15kN

RODS LOCITE INTO THE BOTTOM BAR (ALL THE WAY)

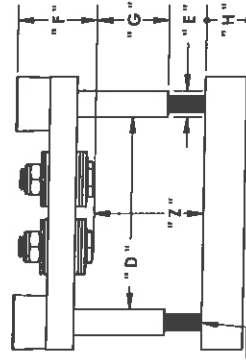
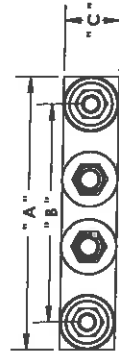

22kN

RODS LOCITE INTO THE BOTTOM BAR (ALL THE WAY)

IC 89 X XX X " Z
 Bolt Centre Style Force " Z "

Part #'s	" Z " min	" Z " max	9kN	15kN	" G " (ref)
IC89 x xx D	1.25 [31.75]	1.50 [38.10]	0.77 [19.55]	1.03 [26.16]	22kN 0.97 [24.63]
IC89 x xx E	1.50 [38.10]	1.75 [44.45]	0.88 [22.35]	1.15 [29.21]	1.09 [27.68]
IC89 x xx F	1.75 [44.45]	2.00 [50.80]	1.00 [25.40]	1.27 [32.25]	1.21 [30.73]
IC89 x xx G	2.00 [50.80]	2.25 [57.15]	1.12 [28.44]	1.37 [34.79]	1.32 [33.52]
IC89 x xx H	2.25 [57.15]	2.50 [63.50]	1.24 [31.49]	1.50 [38.10]	1.44 [36.57]
IC89 x xx J	2.50 [63.50]	2.75 [69.85]	1.36 [35.54]	1.62 [42.14]	1.56 [39.62]
IC89 x xx K	2.75 [69.85]	3.00 [76.20]	1.47 [37.33]	1.70 [43.18]	1.64 [41.65]
IC89 x xx L	3.00 [76.20]	3.25 [82.55]	1.59 [40.38]	1.86 [47.24]	1.80 [45.72]
IC89 x xx M	3.25 [82.55]	3.50 [88.90]	1.71 [43.43]	1.98 [50.29]	1.91 [48.51]
IC89 x xx N	3.50 [88.90]	3.75 [95.25]	1.79 [45.46]	2.10 [53.34]	2.03 [51.56]
IC89 x xx P	3.75 [95.25]	4.00 [101.60]	1.95 [49.53]	2.21 [56.13]	2.15 [54.61]
IC89 x xx Q	4.00 [101.60]	4.25 [107.95]	2.07 [52.57]	2.33 [59.18]	2.27 [57.65]
IC89 x xx R	4.25 [107.95]	4.50 [114.30]	2.18 [55.37]	2.45 [62.23]	2.39 [60.70]
IC89 x xx S	4.50 [114.30]	4.75 [120.65]	2.30 [58.42]	2.57 [65.27]	2.51 [63.75]

" A "	=	4.44 [112.78]
" B "	=	3.50 [89.00]
" C "	=	1.00 [25.40]
" D "	=	2.95 [75.00]
" H "	=	0.50 [12.70]

Force [kN]	" E "	" F " (ref)	Bolt Type
9	0.48 [12.19]	1.60 [40.55]	M8
15	0.48 [12.19]	1.41 [35.79]	M8
22	0.48 [12.19]	1.47 [37.37]	M8

- * All dimensions are in Inches [Millimeters].
- * Modifications available on request.
- * Our standard is Metric but imperial can be accommodated.
- ** "Ref" dimensions due to compression of springs.

IC102 Series

Style 'C'

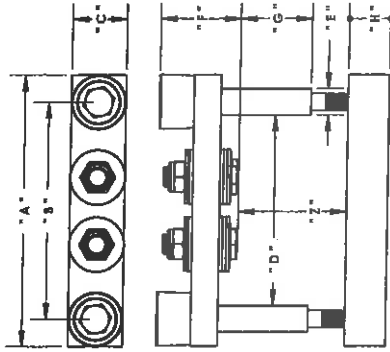

15kN & 22kN

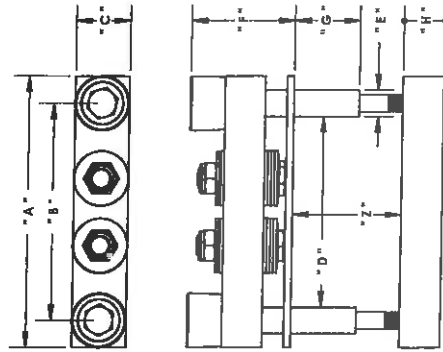

30kN

Style 'D'

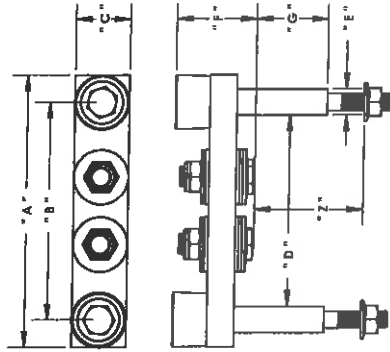

15kN & 22kN

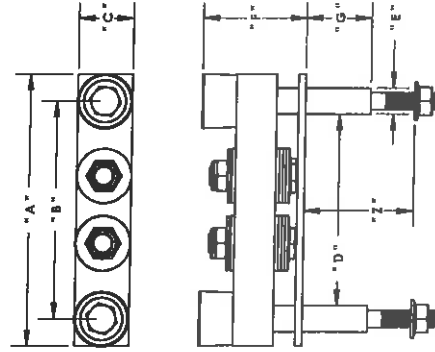

30kN

Style 'F'

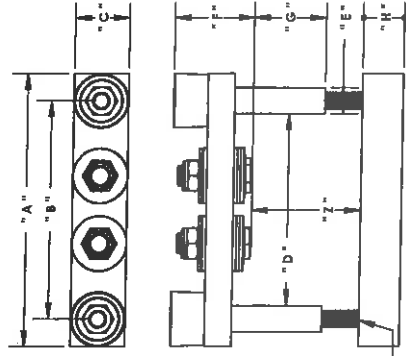

RODS LOCATE INTO
THE BOTTOM BAR
[ALL THE WAY]

15kN & 22kN

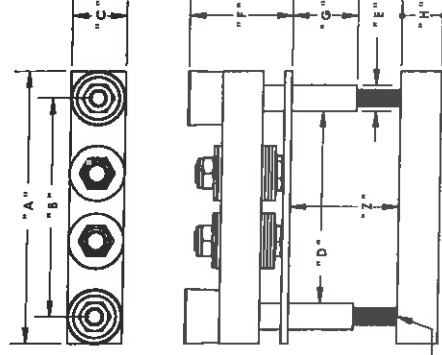

RODS LOCATE INTO
THE BOTTOM BAR
[ALL THE WAY]

30kN

IC 102 X XX X
 Bolt Centre Style Force "Z"

Part #'s	"Z" min	"Z" max	"G" (ref)		
			15kN	22kN	30kN
IC102 x XX D	1.25 [31.75]	1.50 [38.10]	1.03 [26.16]	1.09 [27.68]	0.97 [24.63]
IC102 x XX E	1.50 [38.10]	1.75 [44.45]	1.15 [29.21]	1.21 [30.73]	1.08 [27.43]
IC102 x XX F	1.75 [44.45]	2.00 [50.80]	1.27 [32.25]	1.32 [33.52]	1.20 [30.48]
IC102 x XX G	2.00 [50.80]	2.25 [57.15]	1.39 [35.30]	1.44 [36.57]	1.32 [33.52]
IC102 x XX H	2.25 [57.15]	2.50 [63.50]	1.50 [38.10]	1.56 [39.62]	1.48 [37.59]
IC102 x XX J	2.50 [63.50]	2.75 [69.85]	1.62 [41.14]	1.64 [41.65]	1.60 [40.64]
IC102 x XX K	2.75 [69.85]	3.00 [76.20]	1.70 [43.18]	1.80 [45.72]	1.74 [43.43]
IC102 x XX L	3.00 [76.20]	3.25 [82.55]	1.86 [47.24]	1.91 [48.51]	1.83 [46.48]
IC102 x XX M	3.25 [82.55]	3.50 [88.90]	1.95 [49.53]	2.03 [51.56]	1.95 [49.53]
IC102 x XX N	3.50 [88.90]	3.75 [95.25]	2.10 [53.34]	2.15 [54.61]	2.07 [52.57]
IC102 x XX P	3.75 [95.25]	4.00 [101.60]	2.21 [56.13]	2.27 [57.65]	2.19 [55.62]
IC102 x XX Q	4.00 [101.60]	4.25 [107.95]	2.33 [59.18]	2.39 [60.70]	2.30 [58.42]
IC102 x XX R	4.25 [107.95]	4.50 [114.30]	2.45 [62.23]	2.51 [63.75]	2.42 [61.46]
IC102 x XX S	4.50 [114.30]	4.75 [120.65]	2.57 [65.27]	2.62 [66.54]	2.54 [64.51]

"A"	=	5.00 [127.00]
"B"	=	4.01 [102.00]
"C"	=	1.00 [25.40]
"D"	=	3.42 [87.00]
"H"	=	0.75 [19.05]

Force [kN]	"E"	"F" (ref)	Bolt Type
15	0.48 [12.19]	1.41 [35.79]	M8
22	0.48 [12.19]	1.91 [48.48]	M8
30	0.48 [12.19]	1.41 [35.79]	M8

- * All dimensions are in inches [Millimeters].
- * Modifications available on request.
- * Our standard is Metric but imperial can be accommodated.
- * "Ref" dimensions due to compression of springs.

IC118 Series

22kN

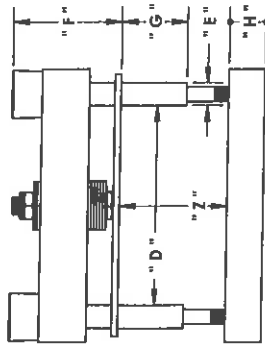
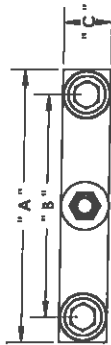

Style 'C'

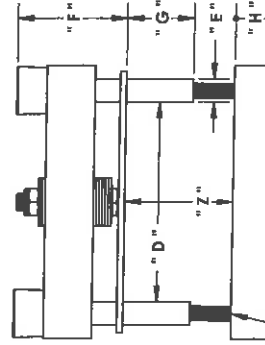
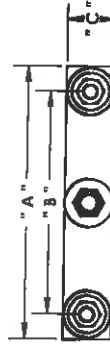

RODS LOCITE INTO THE BOTTOM BAR [ALL THE WAY]

32kN

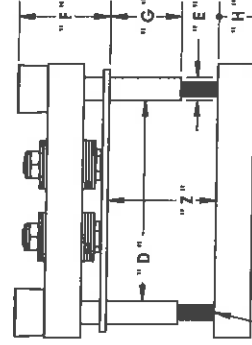
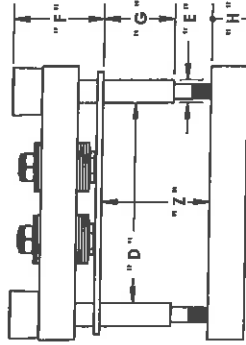

RODS LOCITE INTO THE BOTTOM BAR [ALL THE WAY]

40kN

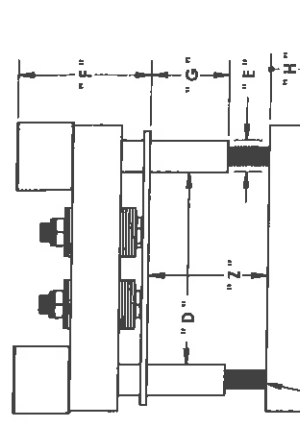
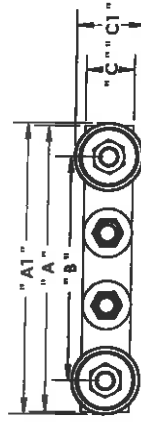
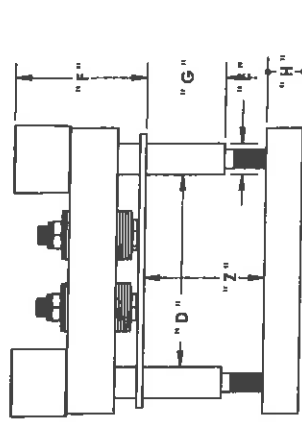
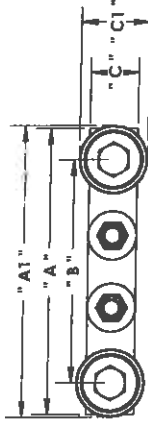

RODS LOCITE INTO THE BOTTOM BAR [ALL THE WAY]

IC 118 X XX X Z
 Bolt Centre Style Force " Z "

" A "	=	5.70 [144.78]	" Z " min	" Z " max	" G " (ref)		
					22kN	32kN	40kN
" A1 "	=	6.07 [154.11]	1.25 [31.75]	1.50 [38.10]	0.98 [24.89]	1.12 [28.44]	1.16 [29.46]
" B "	=	4.64 [118.00]	1.50 [38.10]	1.75 [44.45]	1.10 [27.94]	1.20 [30.48]	1.28 [32.51]
" C "	=	1.00 [25.40]	1.75 [44.45]	2.00 [50.80]	1.26 [32.00]	1.36 [34.54]	1.40 [35.56]
" C1 "	=	1.42 [36.00]	2.00 [50.80]	2.25 [57.15]	1.38 [35.05]	1.48 [37.59]	1.52 [38.60]
" D "	=	4.05 [103.00]	2.25 [57.15]	2.50 [63.50]	1.50 [38.10]	1.60 [40.64]	1.64 [41.65]
" H "	=	0.75 [19.05]	2.50 [63.50]	2.75 [69.85]	1.61 [40.89]	1.71 [43.43]	1.76 [44.70]
			2.75 [69.85]	3.00 [76.20]	1.73 [43.94]	1.83 [46.48]	1.87 [47.49]
			3.00 [76.20]	3.25 [82.55]	1.85 [46.99]	1.95 [49.53]	1.99 [50.54]
			3.25 [82.55]	3.50 [88.90]	1.97 [50.03]	2.07 [52.57]	2.11 [53.59]
			3.50 [88.90]	3.75 [95.25]	2.09 [53.08]	2.19 [55.62]	2.23 [56.64]
			3.75 [95.25]	4.00 [101.60]	2.21 [56.13]	2.30 [58.42]	2.35 [59.69]
			4.00 [101.60]	4.25 [107.95]	2.32 [58.92]	2.42 [61.46]	2.46 [62.48]
			4.25 [107.95]	4.50 [114.30]	2.44 [61.97]	2.54 [64.51]	2.58 [65.53]
			4.50 [114.30]	4.75 [120.65]	2.56 [65.02]	2.66 [67.56]	2.70 [68.58]

Force [kN]	" E "	" F " (ref)	Bolt Type
22	0.48 [12.19]	2.28 [57.99]	M8
32	0.48 [12.19]	1.91 [48.48]	M8
40	0.65 [16.56]	2.77 [70.41]	M10

- * All dimensions are in inches [Millimeters].
- * Modifications available on request.
- * Our standard is Metric but imperial can be accommodated.
- * "Ref" dimensions due to compression of springs.

IC132 Series

Style 'C'

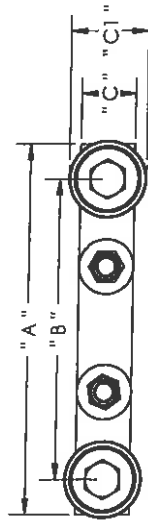

Style 'F'

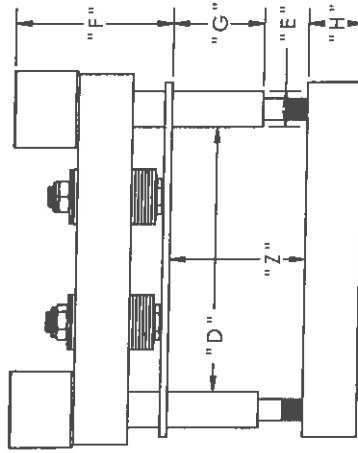
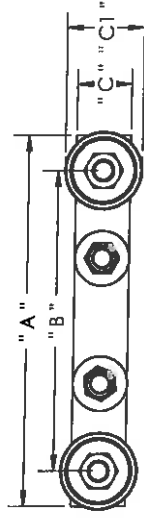

RODS LOCITE INTO
THE BOTTOM BAR
(ALL THE WAY)

28kN, 32kN, 38kN, 45kN

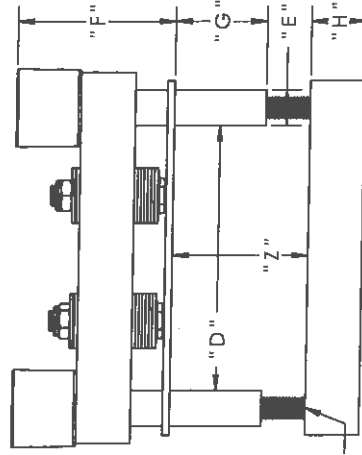

28kN, 32kN, 38kN, 45kN

IC 132 X XX X
 Bolt Centre Style Force "Z"

"A" = 6.50 [165.02]
 "B" = 5.20 [132.00]
 "C" = 1.00 [25.40]
 "C1" = 1.42 [36.00]
 "D" = 4.41 [112.00]
 "H" = 1.00 [25.40]

Part #s	"Z" min	"Z" max	"G" (ref)			
			28kN	32kN	38kN	45kN
IC132 x xx D	1.25 [31.75]	1.50 [38.10]	0.95 [24.13]	1.15 [29.21]	1.16 [29.46]	1.18 [29.97]
IC132 x xx E	1.50 [38.10]	1.75 [44.45]	1.07 [27.17]	1.27 [32.25]	1.28 [32.51]	1.40 [33.02]
IC132 x xx F	1.75 [44.45]	2.00 [50.80]	1.19 [30.22]	1.38 [35.05]	1.40 [35.56]	1.42 [36.06]
IC132 x xx G	2.00 [50.80]	2.25 [57.15]	1.31 [33.27]	1.50 [38.10]	1.52 [38.60]	1.54 [39.11]
IC132 x xx H	2.25 [57.15]	2.50 [63.50]	1.42 [36.06]	1.62 [41.14]	1.64 [41.65]	1.65 [41.91]
IC132 x xx J	2.50 [63.50]	2.75 [69.85]	1.54 [39.11]	1.74 [44.19]	1.76 [44.70]	1.77 [44.95]
IC132 x xx K	2.75 [69.85]	3.00 [76.20]	1.66 [42.16]	1.86 [47.24]	1.87 [47.49]	1.89 [48.00]
IC132 x xx L	3.00 [76.20]	3.25 [82.55]	1.78 [45.21]	1.98 [50.29]	1.99 [50.54]	2.01 [51.05]
IC132 x xx M	3.25 [82.55]	3.50 [88.90]	1.90 [48.26]	2.09 [53.08]	2.11 [53.59]	2.13 [54.10]
IC132 x xx N	3.50 [88.90]	3.75 [95.25]	2.01 [51.05]	2.21 [56.13]	2.23 [56.64]	2.24 [56.89]
IC132 x xx P	3.75 [95.25]	4.00 [101.60]	2.13 [54.10]	2.33 [59.18]	2.35 [59.69]	2.36 [59.94]
IC132 x xx Q	4.00 [101.60]	4.25 [107.95]	2.25 [57.15]	2.45 [62.23]	2.46 [62.48]	2.48 [62.99]
IC132 x xx R	4.25 [107.95]	4.50 [114.30]	2.37 [60.19]	2.57 [65.27]	2.58 [65.53]	2.60 [66.04]
IC132 x xx S	4.50 [114.30]	4.75 [120.65]	2.49 [63.24]	2.68 [68.07]	2.70 [68.58]	2.72 [69.08]

Force [kN]	"E"	"F" (ref)	Bolt Type
28	0.65 [16.56]	2.71 [68.83]	M10
32	0.65 [16.56]	2.71 [68.83]	M10
38	0.65 [16.56]	2.77 [70.41]	M10
45	0.65 [16.56]	2.73 [71.99]	M10

- * All dimensions are in Inches [Millimeters].
- * Modifications available on request.
- * Our standard is Metric but imperial can be accommodated.
- * "Ref" dimensions due to compression of springs.

IC140 Series

Style 'C'

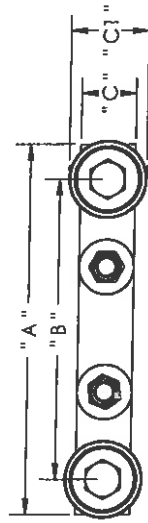

Style 'F'

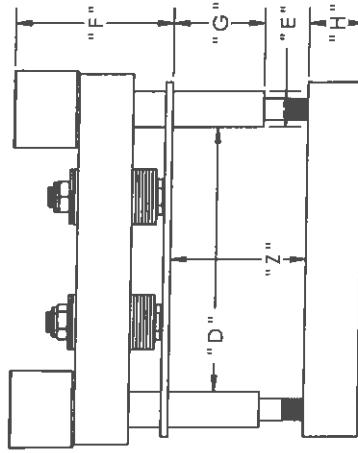
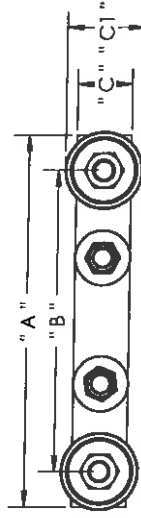

38kN, 45kN, 50kN

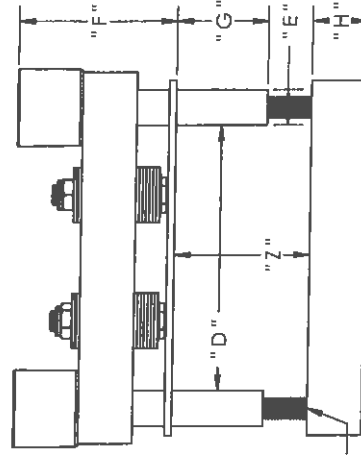

RODS LOCTITE INTO
THE BOTTOM BAR
(ALL THE WAY)

38kN, 45kN, 50kN

IC **140** **X** **XX** **X**
Bolt Centre **Style** **Force** **" Z "**

" A " = **6.80 [172.72]**
" B " = **5.51 [140.00]**
" C " = **1.00 [25.40]**
" C1 " = **1.42 [36.00]**
" D " = **4.72 [120.00]**
" H " = **1.00 [25.40]**

Part #'s	" Z " min	" Z " max	" G " (ref)		
			38kN	45kN	50kN
IC140 x XX F	1.75 [44.45]	2.00 [50.80]	1.40 [35.56]	1.50 [38.10]	1.43 [36.32]
IC140 x XX G	2.00 [50.80]	2.25 [57.15]	1.52 [38.60]	1.61 [40.89]	1.55 [39.37]
IC140 x XX H	2.25 [57.15]	2.50 [63.50]	1.64 [41.65]	1.73 [43.94]	1.67 [42.41]
IC140 x XX J	2.50 [63.50]	2.75 [69.85]	1.76 [44.70]	1.85 [46.99]	1.79 [45.46]
IC140 x XX K	2.75 [69.85]	3.00 [76.20]	1.87 [47.49]	1.97 [50.03]	1.91 [48.51]
IC140 x XX L	3.00 [76.20]	3.25 [82.55]	1.99 [50.54]	2.09 [53.08]	2.02 [51.30]
IC140 x XX M	3.25 [82.55]	3.50 [88.90]	2.11 [53.59]	2.21 [56.13]	2.14 [54.35]
IC140 x XX N	3.50 [88.90]	3.75 [95.25]	2.23 [56.64]	2.32 [58.92]	2.26 [57.40]
IC140 x XX P	3.75 [95.25]	4.00 [101.60]	2.35 [59.69]	2.44 [61.97]	2.38 [60.45]
IC140 x XX Q	4.00 [101.60]	4.25 [107.95]	2.46 [62.48]	2.56 [65.02]	2.50 [63.50]
IC140 x XX R	4.25 [107.95]	4.50 [114.30]	2.58 [65.53]	2.68 [68.07]	2.62 [66.54]
IC140 x XX S	4.50 [114.30]	4.75 [120.65]	2.70 [68.58]	2.80 [71.12]	2.73 [69.34]

Force [kN]	" E "	" F " (ref)	Bolt Type
38	0.65 [16.56]	2.77 [70.34]	M10
45	0.65 [16.56]	2.83 [71.99]	M10
50	0.65 [16.56]	2.90 [73.57]	M10

- * All dimensions are in Inches [Millimeters].
- * Modifications available on request.
- * Our standard is Metric but imperial can be accommodated.
- * "Ref" dimensions due to compression of springs.

IC146 Series

Style 'C'

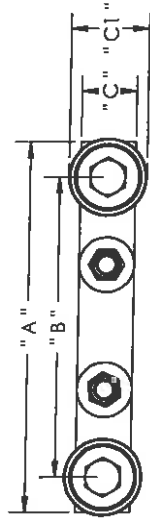

Style 'F'

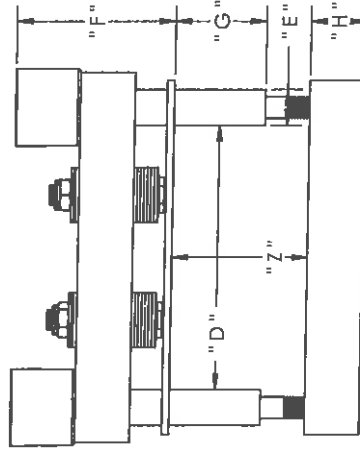
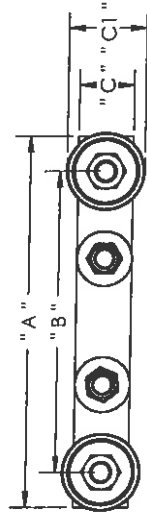

38kN, 45kN, 50kN

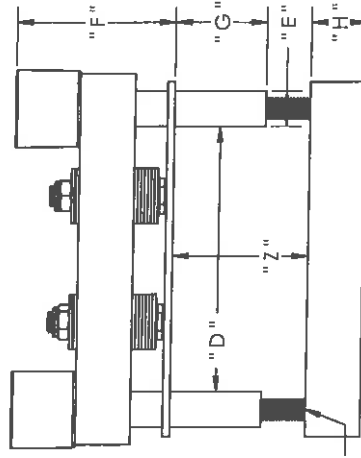

RODS LOCATE INTO
THE BOTTOM BAR
(ALL THE WAY)

38kN, 45kN, 50kN

IC 146 XX X X
 Bolt Centre Style Force " Z "

" A " = 7.13 [181.10]
 " B " = 5.75 [146.00]
 " C " = 1.00 [25.40]
 " C1 " = 1.42 [36.00]
 " D " = 4.96 [126.00]
 " H " = 1.00 [25.40]

Part #'s	" Z " min	" Z " max	" G " (ref)		
			38kN	45kN	50kN
IC146 x xx F	1.75 [44.45]	2.00 [50.80]	1.40 [35.56]	1.50 [38.10]	1.43 [36.32]
IC146 x xx G	2.00 [50.80]	2.25 [57.15]	1.52 [38.60]	1.61 [40.89]	1.55 [39.37]
IC146 x xx H	2.25 [57.15]	2.50 [63.50]	1.64 [41.65]	1.73 [43.94]	1.67 [42.41]
IC146 x xx J	2.50 [63.50]	2.75 [69.85]	1.76 [44.70]	1.85 [46.99]	1.79 [45.46]
IC146 x xx K	2.75 [69.85]	3.00 [76.20]	1.87 [47.49]	1.97 [50.03]	1.91 [48.51]
IC146 x xx L	3.00 [76.20]	3.25 [82.55]	1.99 [50.54]	2.09 [53.08]	2.02 [51.30]
IC146 x xx M	3.25 [82.55]	3.50 [88.90]	2.11 [53.59]	2.21 [56.13]	2.14 [54.35]
IC146 x xx N	3.50 [88.90]	3.75 [95.25]	2.23 [56.64]	2.32 [58.92]	2.26 [57.40]
IC146 x xx P	3.75 [95.25]	4.00 [101.60]	2.35 [59.69]	2.44 [61.97]	2.38 [60.45]
IC146 x xx Q	4.00 [101.60]	4.25 [107.95]	2.46 [62.48]	2.56 [65.02]	2.50 [63.50]
IC146 x xx R	4.25 [107.95]	4.50 [114.30]	2.58 [65.53]	2.68 [68.07]	2.62 [66.54]
IC146 x xx S	4.50 [114.30]	4.75 [120.65]	2.70 [68.58]	2.80 [71.12]	2.73 [69.34]

Force [kN]	" E "	" F " (ref)	Bolt Type
38	0.65 [16.56]	2.77 [70.34]	M10
45	0.65 [16.56]	2.83 [71.99]	M10
50	0.65 [16.56]	2.90 [73.57]	M10

- * All dimensions are in Inches [Millimeters].
- * Modifications available on request.
- * Our standard is Metric but imperial can be accommodated.
- * "Ref" dimensions due to compression of springs.

IC180 Series

Style 'C'

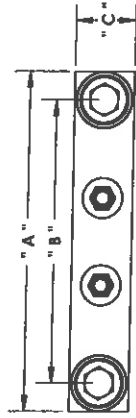

Style 'F'

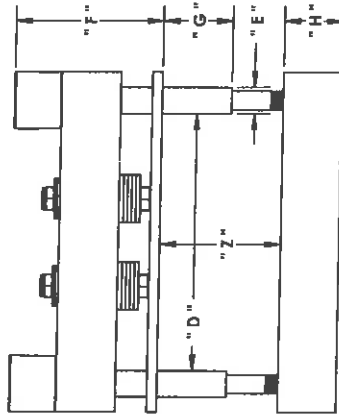
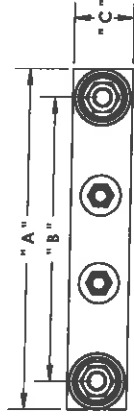

80kN & 90kN

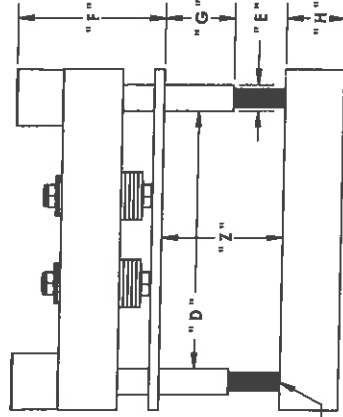

PORE LOCITE INTO
THE MOUNTING
[ALL THE WAY]

80kN & 90kN

IC 180 X XX X
 Bolt Centre Style Force " Z "

" A " = 8.51 [216.07]
 " B " = 7.09 [180.00]
 " C " = 1.50 [38.10]
 " D " = 6.29 [160.00]
 " H " = 1.50 [38.10]

Force [kN]	" E "	" F " (ref)	Bolt Type
80	0.65 [16.56]	3.61 [91.66]	M12
90	0.65 [16.56]	3.71 [94.33]	M12 - Class 10.9

Part #'s	" Z " min	" Z " max	" G " (ref)	
			80kN	90kN
IC180 x xx F	1.75 [44.45]	2.00 [50.80]	1.23 [31.24]	1.24 [31.49]
IC180 x xx G	2.00 [50.80]	2.25 [57.15]	1.35 [34.29]	1.36 [34.54]
IC180 x xx H	2.25 [57.15]	2.50 [63.50]	1.47 [37.33]	1.48 [37.59]
IC180 x xx J	2.50 [63.50]	2.75 [69.85]	1.59 [40.38]	1.60 [40.64]
IC180 x xx K	2.75 [69.85]	3.00 [76.20]	1.70 [43.18]	1.72 [43.68]
IC180 x xx L	3.00 [76.20]	3.25 [82.55]	1.82 [46.22]	1.83 [46.48]
IC180 x xx M	3.25 [82.55]	3.50 [88.90]	1.94 [49.27]	1.95 [49.53]
IC180 x xx N	3.50 [88.90]	3.75 [95.25]	2.06 [52.32]	2.07 [52.57]
IC180 x xx P	3.75 [95.25]	4.00 [101.60]	2.18 [55.37]	2.19 [55.62]
IC180 x xx Q	4.00 [101.60]	4.25 [107.95]	2.29 [58.16]	2.31 [58.67]
IC180 x xx R	4.25 [107.95]	4.50 [114.30]	2.41 [61.21]	2.43 [61.72]
IC180 x xx S	4.50 [114.30]	4.75 [120.65]	2.53 [64.26]	2.54 [64.51]

- * All dimensions are in Inches [Millimeters].
- * Modifications available on request.
- * Our standard is Metric but Imperial can be accommodated.
- * "Ref" dimensions due to compression of springs.

